

TCO2114

Domestic, Std. Export  
& European Export

ENGLISH/German  
French/Spanish



P/N 43336  
Rev. B • V1 • 5/00

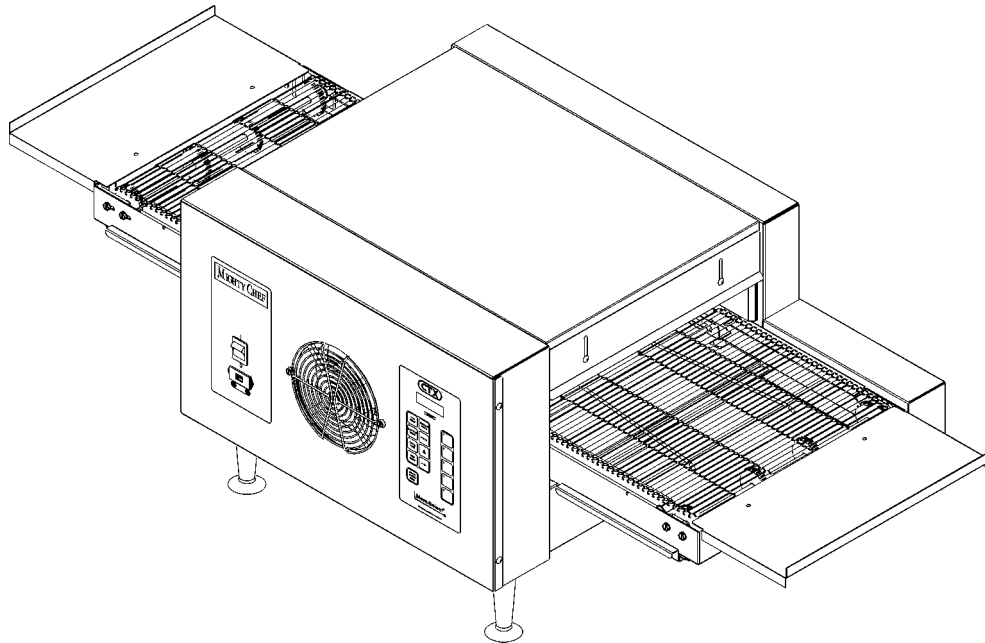

ENGLISH  
page 1

DEUTSCH  
seite 13

FRANÇAIS  
page 25

ESPAÑOL  
página 37

# MIGHTY CHEF™ Conveyor Oven

## Models:

- TCO21140063 (USA & std. export, 208V)
- TCO21140066 (USA & std. export, 240V)
- TCO21140035 (European export, 230V)
- TCO21140077 (European export, 380-400V)

## Combinations:

- Single Oven
- Double Oven (Two-Stack)
- Triple Oven (Three-Stack)

## OWNER'S OPERATING & INSTALLATION MANUAL

© 2000 CTX, A Middleby Company

 is a registered trademark of Middleby Marshall, Inc. All rights reserved.  
Middleby Cooking Systems Group • 1400 Toastmaster Drive • Elgin, IL 60120 • (847)741-3300 • FAX (847)741-4406



**WARNING: IN CASE OF FIRE**  
 Disconnect the oven from its power source IMMEDIATELY. Shutting down the electrical heating elements allows the unit to cool, making it easier to put out the fire.

**WARNING: FOR YOUR SAFETY**  
 DO NOT STORE OR USE GASOLINE OR OTHER FLAMMABLE VAPORS OR LIQUIDS IN THE VICINITY OF THIS OR ANY OTHER APPLIANCE

**WARNING**  
**IMPROPER INSTALLATION, ADJUSTMENT, ALTERATION, SERVICE OR MAINTENANCE CAN CAUSE PROPERTY DAMAGE, INJURY OR DEATH. READ THE INSTALLATION AND OPERATING INSTRUCTIONS THOROUGHLY BEFORE INSTALLING OR SERVICING THIS EQUIPMENT.**

**WARNING**  
 DISCONNECT THE OVEN FROM ITS ELECTRICAL POWER SUPPLY BEFORE CLEANING OR SERVICING.

**CAUTION**  
 Using any parts other than genuine CTX factory parts relieves the manufacturer of all liability.

**IMPORTANT**  
 Contact your authorized service agent to perform maintenance and repairs. A service agency directory is supplied with your oven.

**IMPORTANT**  
 CTX (manufacturer) reserves the right to change specifications and product design without notice. Such revisions do not entitle the buyer to corresponding changes, improvements, additions or replacements for previously purchased equipment.

**RETAIN THIS MANUAL FOR FUTURE REFERENCE**  
 This manual provides detailed information for the installation and operation of your conveyor oven. It also contains information to assist the operator in diagnosing problems in the event of a malfunction. This manual is an important tool for the operator and should be kept readily available.

## TABLE OF CONTENTS

<b>SECTION 1</b>	
<b>DESCRIPTION .....</b>	<b>3</b>
A. Features .....	3
B. Component Location and Function .....	3
C. Electrical Specifications .....	3
<b>SECTION 2</b>	
<b>INSTALLATION .....</b>	<b>4</b>
A. Installation Options and Kit Availability .....	4
B. Assembly .....	4
C. Electrical Connection .....	4
<b>SECTION 3</b>	
<b>OPERATION .....</b>	<b>5</b>
A. Location and Function of Controls .....	5
B. Daily Startup Procedure .....	5
C. Operation .....	6
D. Shutdown Procedure .....	6
E. Programming Preset Menu Selections .....	7
F. Cooking Time and Temperature Guidelines .....	8
G. Draft Curtain Adjustment .....	8
H. Daily Cleaning .....	9
I. Display Messages and Error Codes .....	10
<b>SECTION 4</b>	
<b>ELECTRICAL WIRING DIAGRAMS .....</b>	<b>11</b>
A. Wiring Diagram and Schematic: TCO21140063 (USA & Std. Export, 208V) and TCO21140066 (USA & Std. Export, 240V) .....	11
B. Wiring Diagram and Schematic: TCO21140035 (European Export, 230V) .....	11
C. Wiring Diagram and Schematic: TCO21140077 (European Export, 380-400V) .....	12

© 2000 CTX, A Middleby Company

 is a registered trademark of CTX, A Middleby Company. All rights reserved.

CTX • 1400 Toastmaster Drive • Elgin, IL 60120 • USA • (847)741-3300 • FAX (847)741-4406

**Middleby Corp 24-Hour Service Hotline 1-800-238-8444**

**[www.middleby.com](http://www.middleby.com)**

# SECTION 1 - DESCRIPTION

ENGLISH

## A. FEATURES

The Model TCO2114 Mighty Chef™ Conveyor Oven is designed to quickly and easily cook, bake, and broil a variety of food products with consistent quality and results. The oven is ideal for preparing pizza, garlic toast, cookies, sandwiches, and other food products.

Features of the Mighty Chef include:

- An electronic, programmable controller that allows up to 5 preset menu selections
- A cool exterior for increased safety
- A 14" (356mm)-wide conveyor belt that can be easily set to operate in either direction
- Adjustable draft curtains that reduce draft into the oven and prevent heat loss into the environment
- Welded and reinforced stainless steel construction
- Fast countertop installation - no additional components required

## B. COMPONENT LOCATION AND FUNCTION

Refer to Fig. 1 for the locations of these components.

- 1-3. Oven controls - see Section 3, **Operation**.
4. Crumb trays (3 total) - Collect crumbs that pass through the conveyor. One center crumb tray is located underneath the center of the conveyor. One end crumb tray is located underneath EACH end of the conveyor.
5. Conveyor end trays - Provide additional loading/exit space at the ends of the conveyor.
6. Conveyor - Transports the product through the oven, and between the top and bottom heating elements.
7. Adjustable draft curtains (2 total) - Reduce draft into the oven and prevent heat loss into the environment.
8. Fan - Cools the interior components of the oven.

**Figure 1 - Component location**

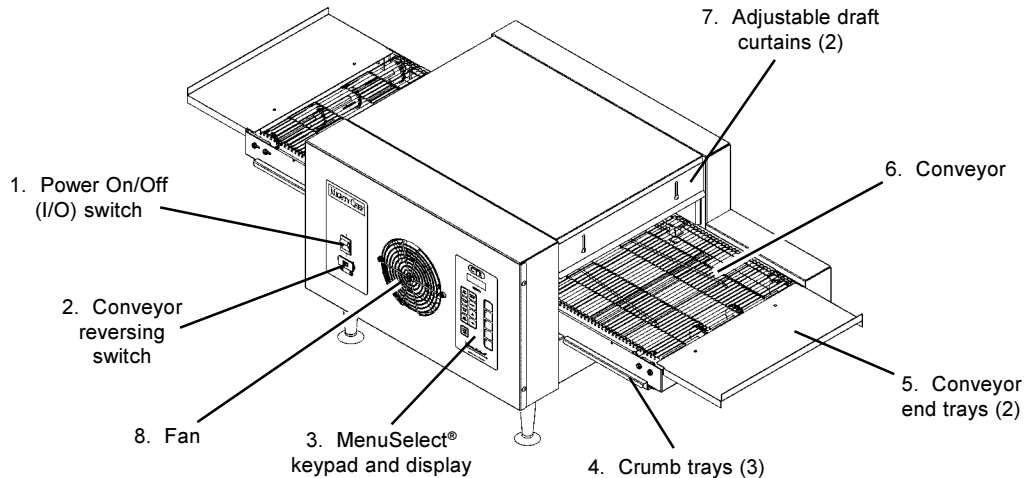

## C. ELECTRICAL SPECIFICATIONS

	<i>TCO21140063</i>	<i>TCO21140066</i>	<i>TCO21140035</i>	<i>TCO21140077</i>
Operating Voltage	208V	240V	230V	380-400V
Frequency	50/60 Hz	50/60 Hz	50 Hz	50 Hz
Phase	1 Ph	1 Ph	1 Ph	3 Ph
kW Rating	5.0kW	5.3kW	5.0kW	5.0kW
Current Draw	24.0A (total)	22.1A (total)	21.1A (total)	
L1	N/A	N/A	N/A	0.3A
L2	N/A	N/A	N/A	10.5A
L3	N/A	N/A	N/A	10.3A
N	N/A	N/A	N/A	10.3A
Cord/Plug Information	Attached cord with NEMA 6-30P plug	Attached cord with NEMA 6-30P plug	Kabelmetal-type HO7RN-F cord with 3 x 4.0mm conductors and moulded-on IEC 309 plug Plug is rated 230VAC, 32A	N/A

# SECTION 2 - INSTALLATION

## IMPORTANT

IT IS THE CUSTOMER'S RESPONSIBILITY TO REPORT ANY CONCEALED OR NON-CONCEALED DAMAGE TO THE FREIGHT COMPANY.

### A. INSTALLATION OPTIONS & KIT AVAILABILITY

If the installation will require two or three ovens to be stacked, you must use the separately-available Stacking Kit (P/N T2114STACK). One Kit is required for a two-stack, while two kits are required for a three-stack. **Stacking more than three ovens is not permitted.**

Wherever the Stacking Kit's instructions are different from those listed below, follow the instructions provided with the Kit.

### B. ASSEMBLY

1. *Installing the Legs*
  - a. Carefully tilt the oven onto its rear side. The front (controller) side should be facing directly upwards.
  - b. Thread the four legs into the holes provided on the bottom of the oven. Tighten them until they are secure.
2. *Installing the Conveyor End Trays*
  - a. Press one of the conveyor end trays down over the end plate of the conveyor frame, as shown in Figure 2.
  - b. Fasten the end tray in place with one of the supplied 8-32x3/8" screws, as shown in Figure 2.
  - c. Repeat the above steps to install the second end tray at the opposite end of the conveyor frame.

## CAUTION

THE SUPPLIED LEGS **AND** THE END TRAYS **MUST BE FASTENED IN PLACE BEFORE OPERATING THE OVEN.**

Figure 2 - End Tray Installation

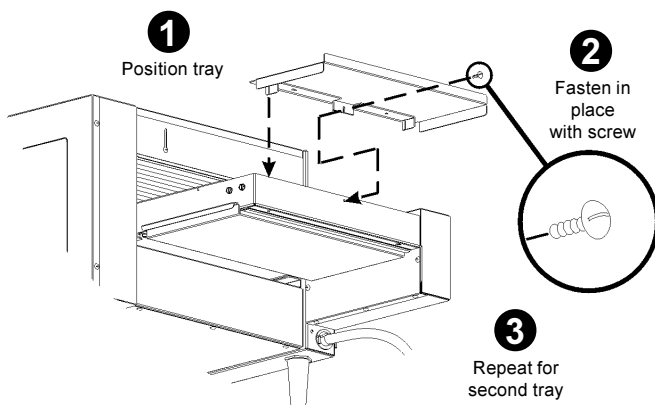

### C. ELECTRICAL CONNECTION

## IMPORTANT

- *Wiring diagrams for the oven are provided on pages 9-10 of this Manual.*
- *The electrical connection to the oven **requires** a circuit breaker/fused disconnect. Consult applicable national and local code requirements to determine the rating of the breaker/disconnect. Electrical specifications are listed on the oven's serial plate and in the Electrical Specifications table (in Section 1 of this Manual).*

- *The toaster's power cord and plug provide an electrical ground connection. A separate equipotential ground connection must also be made if required by national or local codes.*
  - *Consult all applicable national and local codes for further electrical connection requirements.*
1. Before proceeding with the electrical connection, check that the electrical supply matches the oven's requirements. Refer to the serial plate and to the Electrical Specifications table (in Section 1 of this Manual).



## WARNING

ENSURE THAT **BOTH** THE CIRCUIT BREAKER/FUSED DISCONNECT **AND** THE POWER ON/OFF (I/O) SWITCH ARE IN THE "O" (OFF) POSITION BEFORE PROCEEDING.



## WARNING

ENSURE THAT ANY PACKING MATERIAL RESIDUE HAS BEEN REMOVED FROM INSIDE THE OVEN'S COOKING CHAMBER.

2. *Single-phase Mighty Chef ovens only:*
  - Check that the appropriate receptacle is available for the power cord plug.
  - Insert the power cord plug into its receptacle.
3. *Three-phase Mighty Chef ovens only:*
  - Remove the two screws that hold the rear cover panel in place; then, remove the cover panel.
  - Insert the end of the electrical supply through the connector shown in Figure 3.
  - Attach the electrical supply wires to their terminal block connections, as shown in Figure 3.
  - Secure the supply wires to the floor of the electrical compartment using the supplied cable clamp. The wires must not interfere with the drive chain and sprocket. See Figure 3.
  - Secure the supply as it passes through the connector on the outside wall of the oven.
  - Replace the rear wall of the oven and fasten it in place.
4. If required by national or local codes, connect an equipotential ground wire to the lug shown in Figure 3. The equipotential ground connection must meet all applicable national and local code requirements.

Figure 3 - Electrical Connections

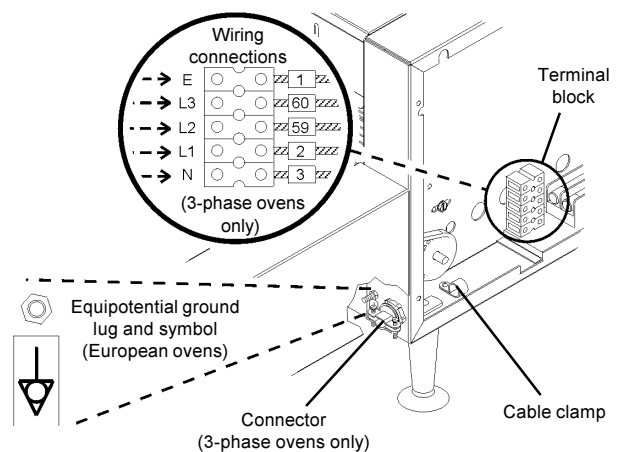

# SECTION 3 - OPERATION

## A. LOCATION AND FUNCTION OF CONTROLS

This section provides a basic description of the Mighty Chef oven's controls, their location, and the functions they perform. The operator MUST be familiar with the controls. See Figure 4.

### 1. MenuSelect® controller

Multi-function keypad which contains the following:

- The display shows the current preset menu selection, temperatures, cook time, or error/service information, depending on the mode of operation.
- The ready light illuminates when both heating zones of the oven have reached their set temperatures.
- The Top Temp key displays/sets the top zone temperature.
- The Bottom Temp key displays/sets the bottom zone temperature.
- The Cook Time key displays/sets the cook time.
- The Ref Temp key displays a reference temperature for the top or bottom heating zone.
- The Sngl Pizza key adjusts the temperature of the top heating zone to properly cook a single pizza, or the last of a group of pizzas.
- The Prog key allows reprogramming of the five Preset Menu Selections.
- The Prog Override key allows a Preset Menu Program to be temporarily changed.

- The Up Arrow and Down Arrow keys are used to edit cook time and temperature settings.
- The Preset Menu keys (1-5) are used to select a Preset Menu to change or operate.

### 2. Power On/Off (I/O) switch

Switches the oven ON ("I") and OFF ("O").

### 3. Conveyor reversing switch

Changes the direction of conveyor travel.

### CAUTION

Do not operate the conveyor reversing switch while the conveyor is in motion.

## B. DAILY STARTUP PROCEDURE

- Adjust the position of the draft curtains at the ends of the cooking chamber (if necessary). This procedure is described in detail in Part G, *Draft Curtain Adjustment*, in this Section.

### IMPORTANT

When cooking at very high temperatures (either heating zone is 400°F / 204°C or higher), the oven should be pre-heated for at least 10 minutes WITH THE DRAFT CURTAINS IN THE FULLY-LOWERED POSITION and both heating zones set to 599°F / 315°C. After pre-heating, the curtains may be repositioned as required.





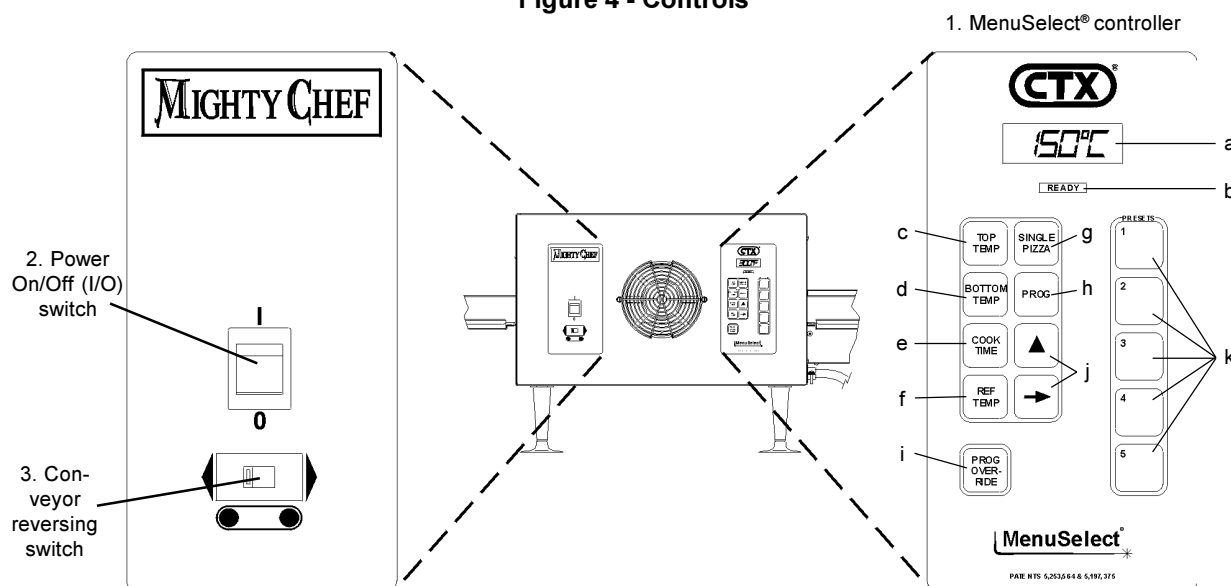







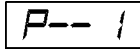

- Restore power to the oven at the circuit breaker/fused disconnect.
- Switch the Power On/Off (I/O) Switch to the ON ("I") position.

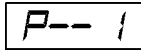
Figure 4 - Controls



ENGLISH

## C. OPERATION

1. **TO PROGRAM A NEW PRESET MENU SELECTION:** Perform the procedure in Part E, *Programming Preset Menu Selections*, in this Section. At least one menu selection **MUST** be programmed before the oven can be operated.
- 
2. **TO TEMPORARILY OVERRIDE A PRESET MENU SELECTION:** Perform the procedure in Part E, *Programming Preset Menu Selections*, **BUT** press  instead of  (in Steps 3 and 8). Instead of permanently overwriting the menu selection, the new set temperature and cook time settings are only temporary. To cancel the temporary menu selection, press any preset menu key or disconnect electrical power to the oven.
- 
3. **TO CHOOSE A PRESET MENU SELECTION:**
- Press  (or any other preset menu key). The display will read . The number in the display ("1" is shown above) will match the menu key that was pressed (1-5).
  - Wait for the  light to illuminate. The light will illuminate after both heating zones reach their set temperatures.
  - Load the product onto the conveyor.
- 
4. **TO COOK A SINGLE PIZZA, OR THE LAST OF A GROUP OF PIZZAS:**
- Choose a preset menu selection, and wait for the  light to illuminate.
  - Press .  and  will alternate in the display. The number in the display ("1" is shown above) will match the current menu selection (1-5).
  - Load the pizza product onto the conveyor.
- IMPORTANT**  
*After 1/2 of the cook time has elapsed, the temperature of the top zone will be automatically lowered. After the entire cook time has elapsed, the program will return to its normal top zone temperature.*
- After  is pressed, the menu selection cannot be changed until the cook time has elapsed.*
- 
5. **TO VIEW THE SET TEMPERATURES:** Press either  or . The top or bottom set temperature will be displayed for 5 seconds.
- 
6. **TO VIEW HEATING ZONE REFERENCE TEMPERATURES:** Press  +  or  + . The top or bottom reference temperature will be displayed for 5 seconds.
- 
7. **TO VIEW THE COOK TIME:** Press . The cook time will be displayed for 5 seconds.









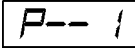

## D. SHUTDOWN PROCEDURE

- Switch the Power On/Off (I/O) switch to the OFF ("O") position.
- Wait for the oven's cooling fan to turn off.
- Disconnect electrical power to the oven at the circuit breaker/fused disconnect.

## E. PROGRAMMING PRESET MENU SELECTIONS



### IMPORTANT

Adding a menu program to the oven will overwrite an existing program. DO NOT enter a new menu program over an existing program that you wish to keep!

1. Restore power to the oven at the circuit breaker/fused disconnect.
2. Switch the Power On/Off (I/O) Switch to the ON ("I") position.
3. Press and hold  until  appears in the display.
4. **CHOOSE A MENU SELECTION TO PROGRAM** Press and hold  (or any other preset menu key) until  appears in the display and begins to flash. The number in the display ("1" is shown above) will match the menu key that was pressed (1-5).
5. **SET TOP TEMPERATURE**
  - a. Press . The current top set temperature appears in the display.
  - b. Press  and  as necessary to change the displayed temperature.
    - Pressing  once increases the "active" (flashing) digit by one. This digit "rolls over" to its minimum value if  is pressed when the digit shows its maximum value.
    - Pressing  once causes the next digit to the right to become the "active" (flashing) digit. If the far-right digit is flashing when  is pressed, the far-left digit will flash and become the "active" digit.



### IMPORTANT

The allowed temperature range is 200-599°F (93-315°C). If you program a set temperature between 0°F (or 0°C) and 99°F (37°C), the heater will be set to OFF. If you program a set temperature between 100°F (38°C) and 199°F (92°C), the temperature will automatically change to 200°F (93°C), the display will flash, and a beep will sound to alert you to the temperature change.

6. **SET BOTTOM TEMPERATURE**
  - a. Press . The current bottom set temperature appears in the display.
  - b. Press  and  as necessary to change the displayed temperature.







### IMPORTANT

Unless you are following specific time and temperature instructions, the top and bottom zone temperatures should be set WITHIN 50°F (28°C) of each other. Greater temperature differences may cause the hotter zone to heat the cooler zone. This can cause inconsistent cooking results.

7. **SET COOK TIME**
  - a. Press . The current cook time appears in the display (minutes : seconds).
  - b. Press  and  as necessary to change the displayed time.

### IMPORTANT

The allowed cook time range is 00:30-15:00. If you program a cook time outside of this range, the time will change to the closest allowed time (00:30 if your time was too short, or 15:00 if it was too long). The display will flash, and a beep will sound to alert you to the changed cook time.

8. Press ONE of the following keys:
  - , , or : Re-enter the top setpoint temperature, bottom set point temperature, or cook time.
  - : Turn off Programming Mode. This returns the oven to normal operation.
  - Any other key except  or : Resume operation, but leave Programming Mode active. Other Preset Menu Selections can be programmed at this time.

## F. COOKING TIME AND TEMPERATURE GUIDELINES

### IMPORTANT

The cooking times and temperatures shown below are recommendations only. You should always test each food product to determine correct time and temperature settings.

PRODUCT	SET TEMPERATURE		COOK TIME
	upper	lower	
Bagel Bites	400°F/204°C	420°F/216°C	5:00
Biscuits	250°F/121°C	335°F/168°C	6:45
Bread Sticks (retherm)	425°F/218°C	475°F/246°C	4:30
Cheese Sticks (frozen)	460°F/238°C	445°F/229°C	6:00
Chicken Nuggets (frozen)	460°F/238°C	445°F/229°C	6:00
Cookies	375°F/191°C	375°F/191°C	9:00
Garlic Bread (retherm)	425°F/218°C	475°F/246°C	2:30
Hamburgers (frozen)	540°F/282°C	540°F/282°C	5:00
Jalapeno Poppers	460°F/238°C	400°F/204°C	6:45
Pizza (fresh), 12" (300mm) dia.	375°F/191°C	480°F/249°C	6:30
Pizza (retherm), slice	425°F/218°C	500°F/260°C	2:15
Pizza (frozen - slacked in refrigerator 12 hrs. before cooking), 6-8" (150-200mm) dia.	380°F/193°C	430°F/221°C	6:30
Pizza, par baked crust	470°F/243°C	525°F/274°C	6:30
Pretzels (pre-cooked)	505°F/263°C	540°F/282°C	0:45
Sandwiches, open-faced	550°F/288°C	550°F/288°C	0:50

## G. DRAFT CURTAIN ADJUSTMENT

The draft curtains may need to be repositioned to provide adequate clearance for some food products. The curtains should be positioned to prevent drafts into the oven, and heat loss into the environment.

The draft curtains can be removed from the oven to permit the maximum vertical clearance above the conveyor.



### WARNING

BEFORE ADJUSTING THE DRAFT CURTAINS, SWITCH THE POWER ON/OFF (I/O) SWITCH TO THE OFF ("O") POSITION.



### CAUTION - HOT

WHEN REPOSITIONING THE CURTAINS:

- WEAR A HEAVY OVEN MITT.
- DO NOT REACH INTO THE OVEN'S COOKING CHAMBER! See Figure 5.

- To reposition the draft curtains:
  - Loosen the two screws that hold the draft curtain in place. See Figure 5.
  - Slide the curtain to the desired clearance above the conveyor.
  - Tighten the two screws to hold the curtain in place.
  - Repeat these steps for the curtain at the opposite end of the oven.
- To remove the curtains from the oven:
  - Remove the two screws that hold the draft curtain in place.
  - Remove the draft curtain.
  - Repeat these steps for the curtain at the opposite end of the oven.

Figure 5  
Repositioning the draft curtains

**DO** keep hands outside of cooking chamber

**DO NOT** reach inside cooking chamber

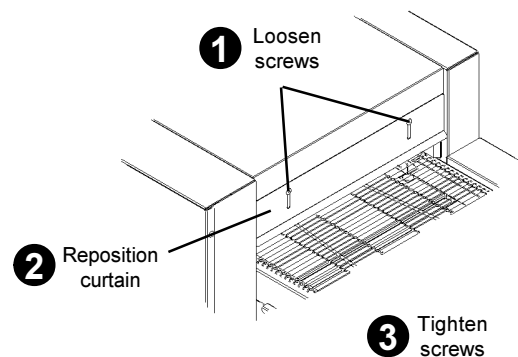
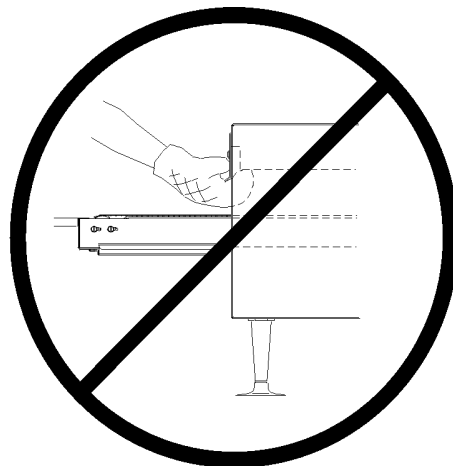
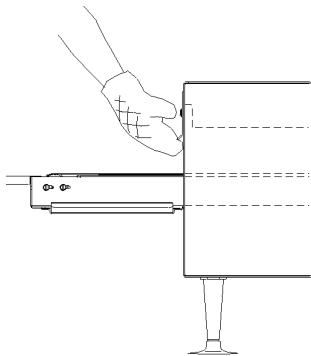

### H. DAILY CLEANING



**WARNING**  
WHEN CLEANING THE OVEN:

- **NEVER USE PRESSURIZED WATER.**
- **NEVER USE A CLEANING SOLUTION OTHER THAN SOAP AND WATER ON PORTIONS OF THE OVEN THAT COME INTO CONTACT WITH FOOD PRODUCTS. THESE AREAS INCLUDE THE CONVEYOR BELT AND END TRAYS.**
- **NEVER APPLY ENOUGH LIQUID TO STAND IN PLACE ON THE OVEN. LIQUID INSIDE THE OVEN WILL CAUSE A SEVERE ELECTRICAL HAZARD AND MAY OTHERWISE DAMAGE THE OVEN.**

#### CAUTION

DO NOT clean your oven using abrasive cleaners or pads. Both will scratch and dull the finish.

1. With the conveyor running, use a brush to clean any crumbs off the conveyor into the crumb trays.
2. Switch the Power On/Off (I/O) switch to the OFF ("O") position, and wait for the cooling fan to turn off.
3. Disconnect electrical power to the oven at the circuit breaker/fused disconnect.
4. Allow the oven to cool.



**CAUTION - HOT**  
DO NOT TOUCH HOT SURFACES ON THE OVEN, OR REACH INTO THE COOKING CHAMBER, UNTIL THE UNIT HAS COOLED THOROUGHLY.

5. Thoroughly clean the fan grill on the front of the oven using a stiff nylon brush. See Figure 6.
6. Clean the end trays USING SOAP AND WATER ONLY and towel them dry. If necessary, the end trays can be removed for cleaning by removing the screws that hold them in place. See Figure 2 (in the Installation section of this Manual).

#### IMPORTANT

If the end trays are removed for cleaning, they must be replaced prior to operating the oven.

7. Slide the end crumb trays out from underneath the entrance and exit ends of the conveyor. See Figure 6.
8. Lift BOTH ends of the center crumb tray; then, slide the tray out of either end of the oven.
9. Clean all three of the crumb trays using a commercial oven cleaner. If necessary, towel them dry.
10. Replace the center crumb tray in the oven as shown in Figure 7.

#### IMPORTANT

Proper positioning of the center crumb tray is **REQUIRED** for proper cooking. Ensure that the tray is replaced inside the conveyor frame, as shown in Figure 7, and **NOT** on the floor of the cooking chamber!

11. Replace the two end crumb trays.
12. Clean the outside of the oven using a damp cloth with EITHER soap and water OR a stainless steel cleaner. Use caution to ensure that liquids do not enter the oven during cleaning, especially when wiping the fan grill.

**Figure 6**  
End crumb trays and fan grill

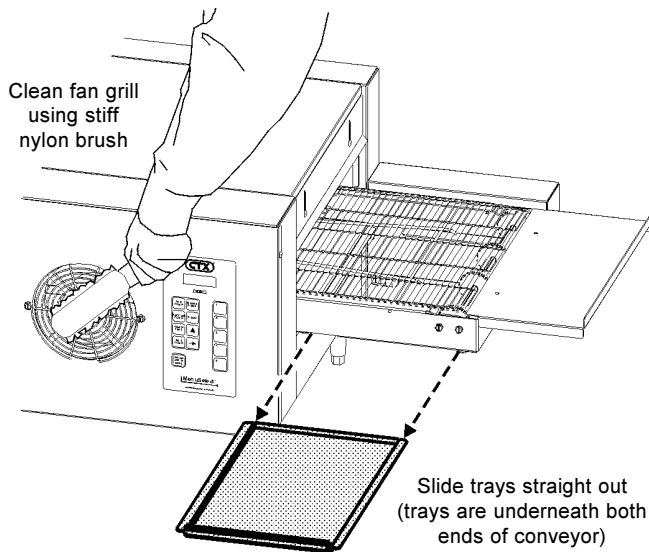

**Figure 7**  
Center crumb tray placement

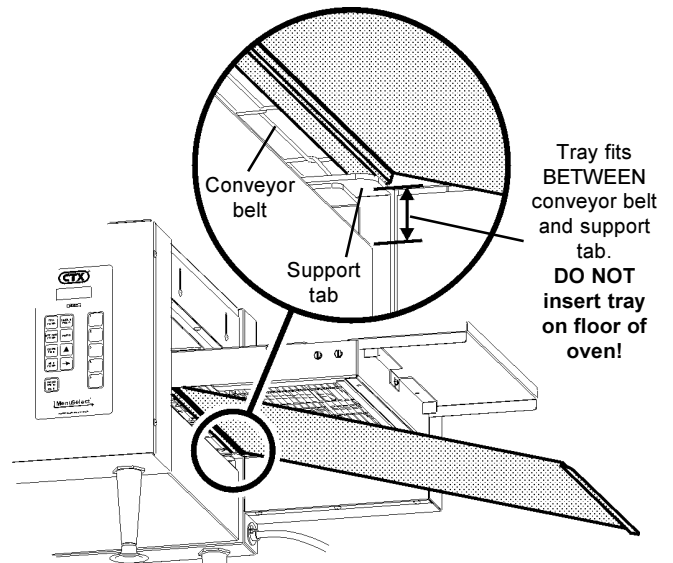

## I. DISPLAY MESSAGES AND ERROR CODES

### DISPLAY SHOWS PROBLEM

### ACTION

Flashing temperatures or cook times during programming, and oven is beeping

*Set Temperatures or Cook Time Outside of Allowed Range*

Re-enter the program using Set Temperatures and Cook Time within the allowed range. Also, refer to Part E, *Programming Preset Menu Selections*, in this Section.

**OFF**

*Heating Element turned off*

If the element should be on, re-enter the program using Set Temperatures within the allowed range. Also, refer to Part E, *Programming Preset Menu Selections*, in this Section.

----

*No Menu Selection Chosen*

Choose or program a preset menu selection.

**E-00**

*Preset Menu Program Lost*

Re-enter the Preset Menu program.

**E-01**

*High Ambient Condition*  
Temperature inside the control enclosure exceeds 65°C. The oven shuts down, then beeps continuously.

Check the cooling fan (centered on the front panel of the oven) for cleanliness and proper operation. If the fan is not running after the oven heats, or the oven remains in a high ambient condition, contact your local Authorized Service Agent.

**E-02**

*Conveyor Runaway*  
The conveyor runs at full speed. The oven shuts down, then beeps continuously.

Check for the proper speed setting by pressing . If the speed setting is correct, and the conveyor continues to run at full speed, contact your Authorized Service Agent.

**E-04**

*Conveyor Loose or Jammed*  
Conveyor is stopped when the speed setting is between 0:15 and 15:00.

Switch the Power On/Off (I/O) Switch to the OFF ("O") position. Switch the breaker/fused disconnect to the OFF position. Allow the oven to cool for at least 30 minutes.



#### CAUTION - HOT

DO NOT ATTEMPT TO FREE A JAMMED CONVEYOR BELT WHILE THE COOKING CHAMBER IS WARM. SEVERE INJURY MAY RESULT.

If the conveyor is jammed, free the obstruction from the conveyor belt. If the conveyor still will not operate properly after the jam is cleared, OR if the error message appears when the conveyor is NOT jammed, contact your local authorized service agent.

**E-35**

*Top Heating Zone Failure*

Contact your local authorized service agent.

**E-36**

*Bottom Heating Zone Failure*

Contact your local authorized service agent.

**E-40**

*Heating Zone Temperature High Limit*  
One or both of the heating zones have reached a temperature greater than 315°C.

Contact your local authorized service agent.

# SECTION 4 - ELECTRICAL WIRING DIAGRAMS

**Wiring Diagram, TCO21140063** (Domestic & Std. Export 208V)  
and **TCO21140066** (Domestic & Std. Export 240V)

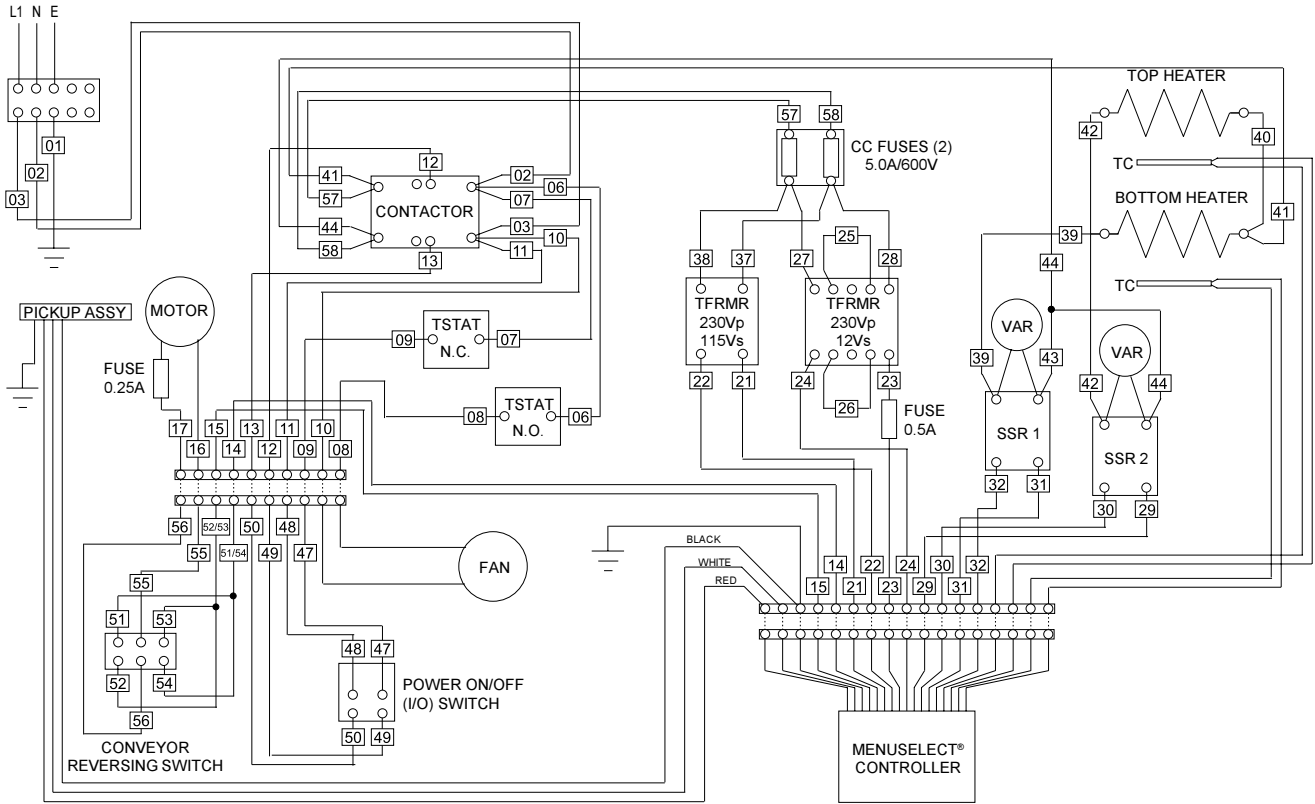

ENGLISH

**Electrical Schematic, TCO21140063** (Domestic & Std. Export 208V)  
and **TCO21140066** (Domestic & Std. Export 240V)

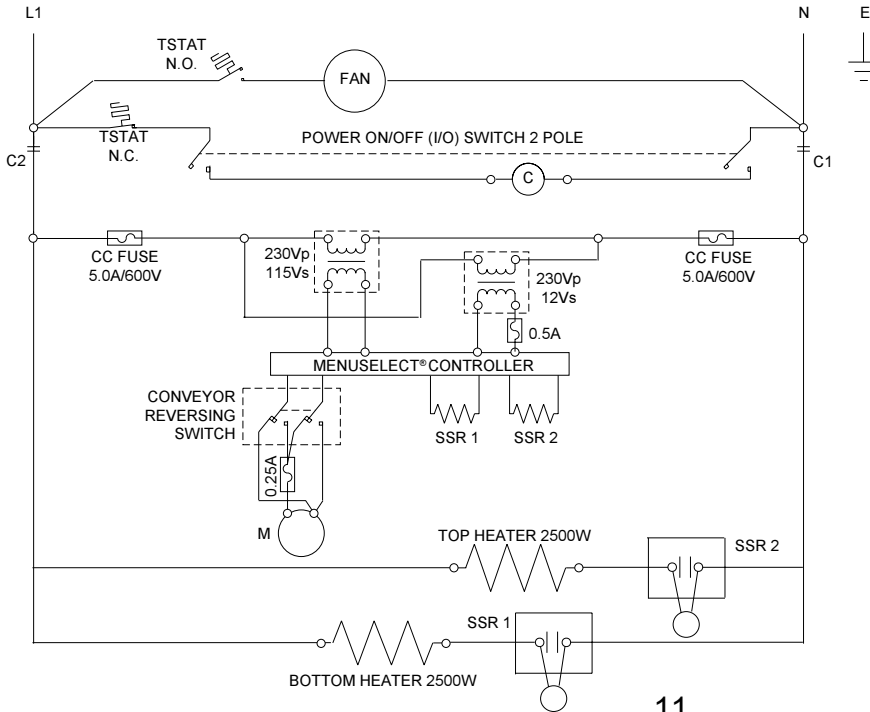

**Wiring Diagram, TCO21140035**  
(European Export 230V)  
Remainder of wiring matches  
TCO21140063/0066

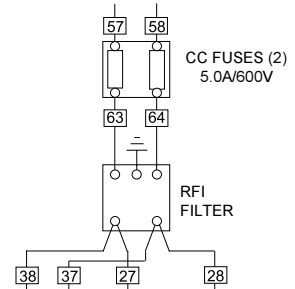

**Electrical Schematic, TCO21140035**  
(European Export 230V)  
Remainder of wiring matches  
TCO21140063/0066

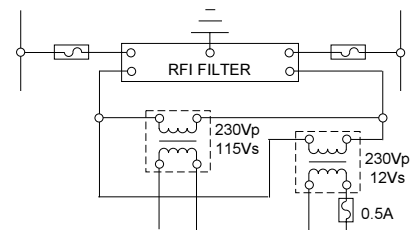

## Wiring Diagram, TCO21140077 (European Export 380-400V)

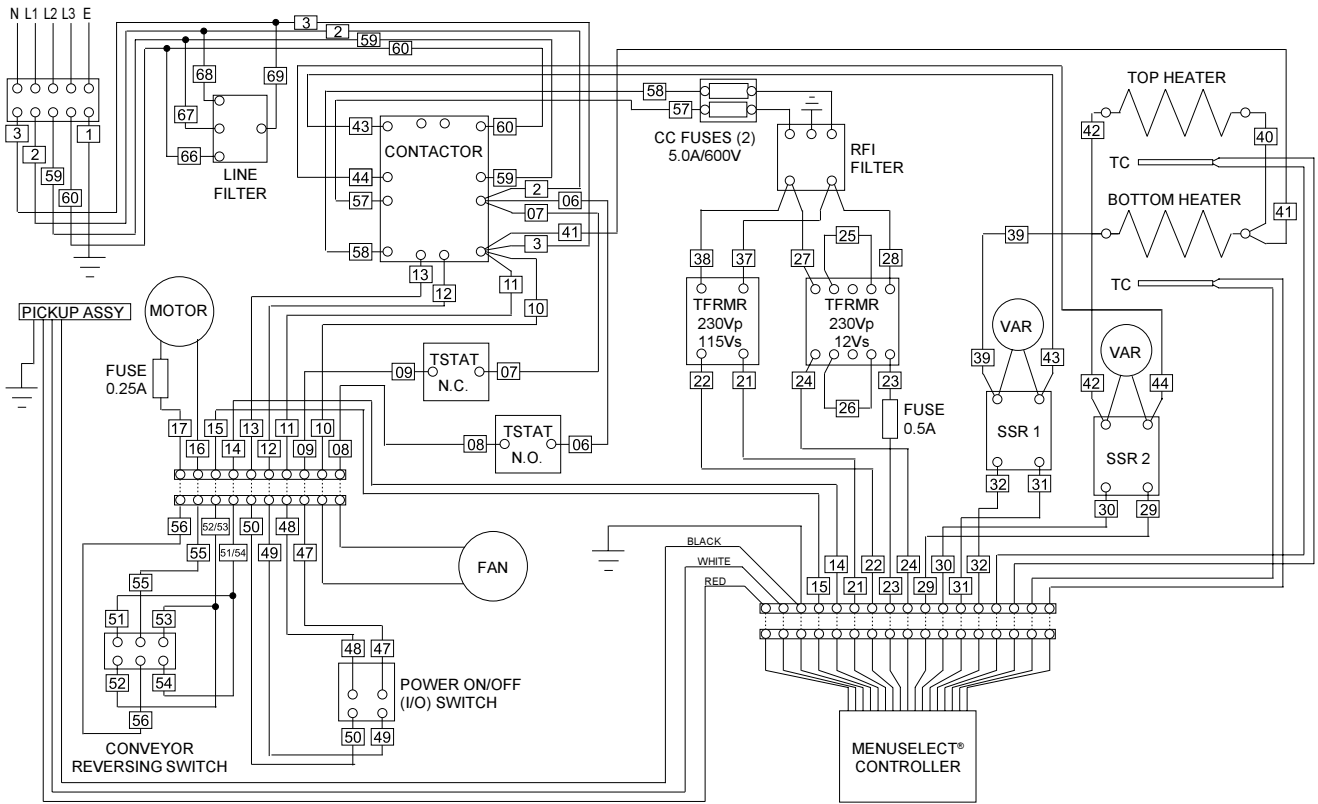

## Electrical Schematic, TCO21140077 (European Export 380-400V)

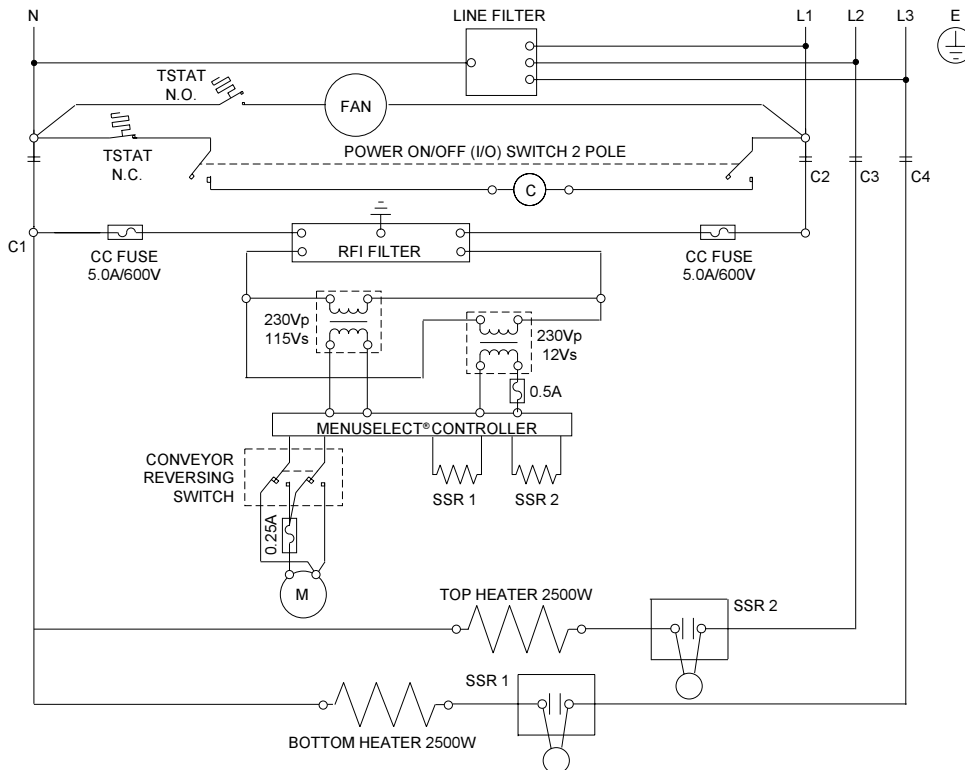

is a registered trademark of CTX, A Middleby Company. All rights reserved.

CTX • 1400 Toastmaster Drive • Elgin, IL 60120 • USA • (847)741-3300 • FAX (847)741-4406

**Middleby Corp 24-Hour Service Hotline 1-800-238-8444**

**[www.middleby.com](http://www.middleby.com)**